

OILQUICK®

ANY MACHINE. ANY ATTACHMENT. ANYTIME.



OilQuickAmericas.com

Manufactured in the USA

CHANGE ANY ATTACHMENT IN SECONDS

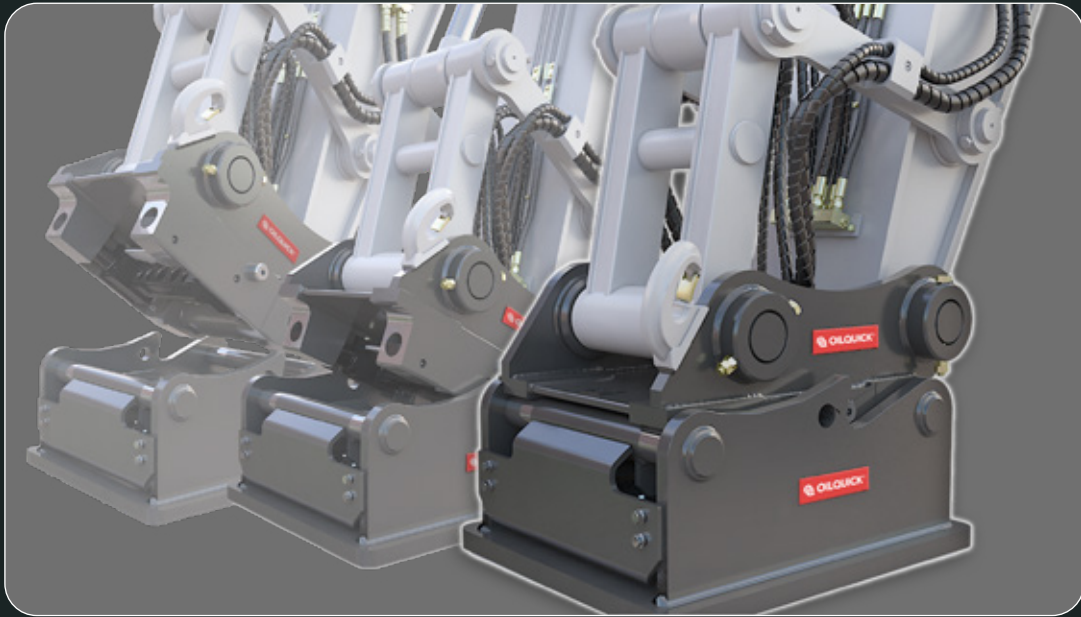

OilQuick automatic quick coupler system allows attachments to be connected and disconnected from the driver's cab within seconds.

**Any Machine.
Any Attachment.
Anytime.**

Excavators

OQ System for Excavators

The coupler locks the attachments in place at full system pressure while engaging with no play, resulting in minimum wear and a long service life for the coupler system.

Model	Width (in.)	Pin Distance (in.)	Weight (lbs.)	Weight of Machine (T)	Max # of Hose Couplers						Electrical Coupling (Optional)
					Max	3/8"	1/2"	3/4"	1"	1.5"	
OQ 40/24	9.44	11.8	66	1 - 5	4	2	2				Yes
OQ 40-5	9.44	11.8	66	1 - 5	5	3	2				Yes
OQ 45-5	11.4	16.9	187	5.5 - 13	5	3	2				Yes
OQ 60-5	13.4	18.9	298	8 - 18	5	2	1	2			Yes
OQ 65	17.3	20.9	375	15 - 24	5		2	3			Yes
OQ 65/Rail	17.32	20.4	375	15 - 24	8		5	3			Yes
OQ 70/55	21.7	23.6	507	20 - 31	6		2	2	2		Yes
OQ 80	23.2	26.4	705	28 - 44	6		2	2	2		Yes
OQ 90	29.5	29.5	1390	44 - 77	9	1	3	1	4		Yes
OQ 120	34.3	36.4	2646	77 - 132	8		3		3	2	Yes



Cranes/Material Handlers

OQC System for Cranes/Material Handlers

Model	Rotator	Number of Quick Couplers				Max. lift capacity (ton)	Dimensions (in.)				
		1"	3/4"	1/2"	3/8"		A	B	C	D	E
OQC65-I20	XR400	-	3	2	-	22	20.9	17.4	28.3	28.6	20.2
OQC65-R20	RT504	-	3	2	-	22	20.9	17.4	28.3	44.4	36.0
OQC65-R25	RT1004	-	3	2	-	27	20.9	17.4	28.3	47.1	38.8
OQC70/55-R35	RT1204	2	2	2	-	38	25.6	21.7	30.7	51.4	42.2
OQC90-R54	RT1204	4	1	3	1	59	37.4	29.6	43.3	58.5	46.4
OQC90-R68	RT1504	4	1	3	1	75	37.4	29.6	43.3	64.4	52.3

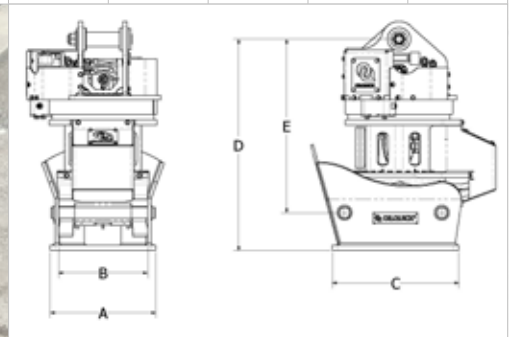

Wheel Loaders

OQL System for Wheel Loaders

Change tools such as log forks, high dumping buckets, pallet forks with hydraulic tine adjustment, sweepers, bale clamps, and rotating bale clamps quickly from the comfort of the cab.



Model	Weight (lbs.)	Width (in.)	Working Pressure (PSI)	Number of Quick Couplers			Electrical Coupling 10-pole (optional)	Carrier Weight ton	Suitable for Volvo Model
				Max	1/2"	3/4"			
OQL 310-1	595	46	5076	6	2*	4	Left hand side	6 - 10 t	L50
OQL 310-2	772	47	5076	6	2*	4	Left hand side	10 - 14 t	L60
OQL 310-3	948	47	5076	6	2*	4	Left hand side	12 - 20 t	L70 - L120
OQL 410	1389	52	5076	6	2*	4	Left hand side	22 - 36 t	L150 - L220

*When using an electrical coupling, one 1/2" quick coupling is replaced
1/2" has a maximum of 18,5GPM (70 L/min)
3/4" has a maximum of 37 GPM (140 L/min)

SAFE TOOL CHANGE

OQ-LockSupport

OQLS facilitates user-friendly driver support for secure attachment switching on excavators, guiding operators through control panel steps with audio and visual signals in hazardous situations.

Sensor detection of attachment pins and locking cylinder position

Sensor detection of attachment pins



Service

Commitment To Service Excellence

Delivering unparalleled service lies at the core of our mission.

Our goal is to elevate the customer experience with our top-tier support. Our team of seasoned field technicians stands ready for on-site technical support and personalized training sessions, ensuring your team is confident.

From live video chats to responsive phone calls and emails, our support is comprehensive and quick. Expect nothing less than expert technicians dispatched to not only deliver exceptional service but also to impart invaluable knowledge to your team.

Contact our service team

715.718.6969

Service@OilQuickAmericas.com



OILQUICK BENEFITS

FAST AND EFFICIENT

The OilQuick quick coupler system enables the operator to change over quickly between various mechanical and hydraulic attachments from inside the cab. Have the right tool for the job in every situation, so you can work faster and more efficiently.

HIGHEST QUALITY

OilQuick quick couplers and tool adapters are of the highest quality and ensure a precision fit. The coupler locks the attachments in place at full system pressure. This ensures engagement with no play resulting in minimum wear and long service life for the coupler system.

SAFE QUICK COUPLER SYSTEM

OilQuick quick coupler systems are safe and secure. Safety features include double hose break valves and a system for constantly re-adjusting the locking bolts hydraulically. The locking is operated via a pressure panel or touch screen.

IMPROVED WORKING CONDITIONS

As work tools are changed and coupled automatically, the operator does not have to get out of the cab. No more handling of couplings covered in oil or leaving the cab with unnecessary exposure to risks. OilQuick boosts morale at work, even in poor weather conditions.

MORE COST EFFECTIVE

Fast tool change and efficient use of the excavator help to increase productivity. Experience has shown that investing in an OilQuick quick coupler pays off when you are changing hydraulic work tools two or more times within a working day.

ECO-FRIENDLY

All OilQuick quick couplers are fitted with leak-free oil quick couplings.

CLEAN SYSTEM PARTNER

A certified partner program to protect the users and create confidence in our trade partners.



MANUFACTURED IN THE USA



In partnership with OilQuick AB, OilQuick Americas started manufacturing automatic couplers and brackets at our 120,000 square foot facility in Superior, Wisconsin USA in 2022.



 **OILQUICK[®]**
Americas

OILQUICKAMERICAS.COM
+1 262.607.8425
INFO@OILQUICKAMERICAS.COM

155 MAIN STREET
SUPERIOR, WISCONSIN 54880 USA

 @OilQuickAmericas  @OilQuickAmericas  /OilQuickAmericas